

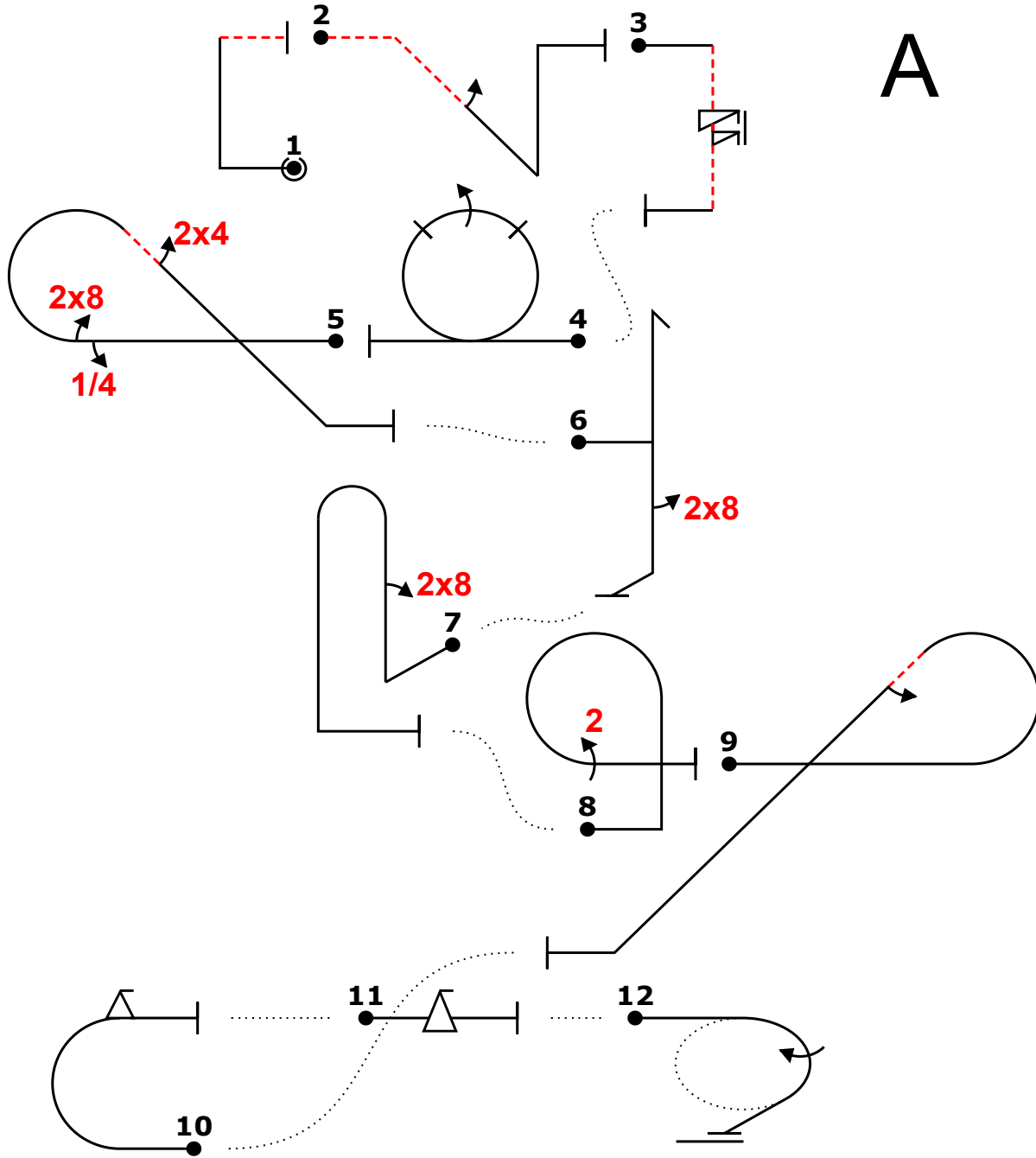

ЧР, Усмань-Шаршки 2021		Form B
Pilot ID	CIVA Intermediate Unknown1	
		Flight #

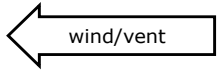

Power			
Fig	Aresti	K	
1	1.1.7.1	9	12
<b>Add.</b>			
2	1.2.4.4 F 9.1.4.2	13 4	17
3	1.1.6.3 A 9.11.1.6	10 3	13
4	7.4.1.1 C 9.1.3.4	10 8	18
5	8.5.6.1 G 9.1.3.1 9.8.3.1 9.4.4.2	10 2 3 5	20
6	5.2.1.1 H 9.8.5.1	17 3	20
7	8.4.1.1 J 9.8.1.1	13 7	20
8	8.6.1.1 E 9.2.3.4	11 9	20
9	8.5.6.1 Add. 9.1.4.2	10 4	12
10	7.2.2.1 D 9.9.3.2	6 11	17
11	1.1.1.1 B 9.9.3.4	2 11	13
12	2.1.3.1 I	14	14
<b>Total K = 196</b>			

\_\_\_\_\_  
Pilot  
.....  
A/C

# Вариант В



ЧР, Усмань-Шаршки 2021		Form B
Pilot ID	CIVA Intermediate Unknown1	
		Flight #

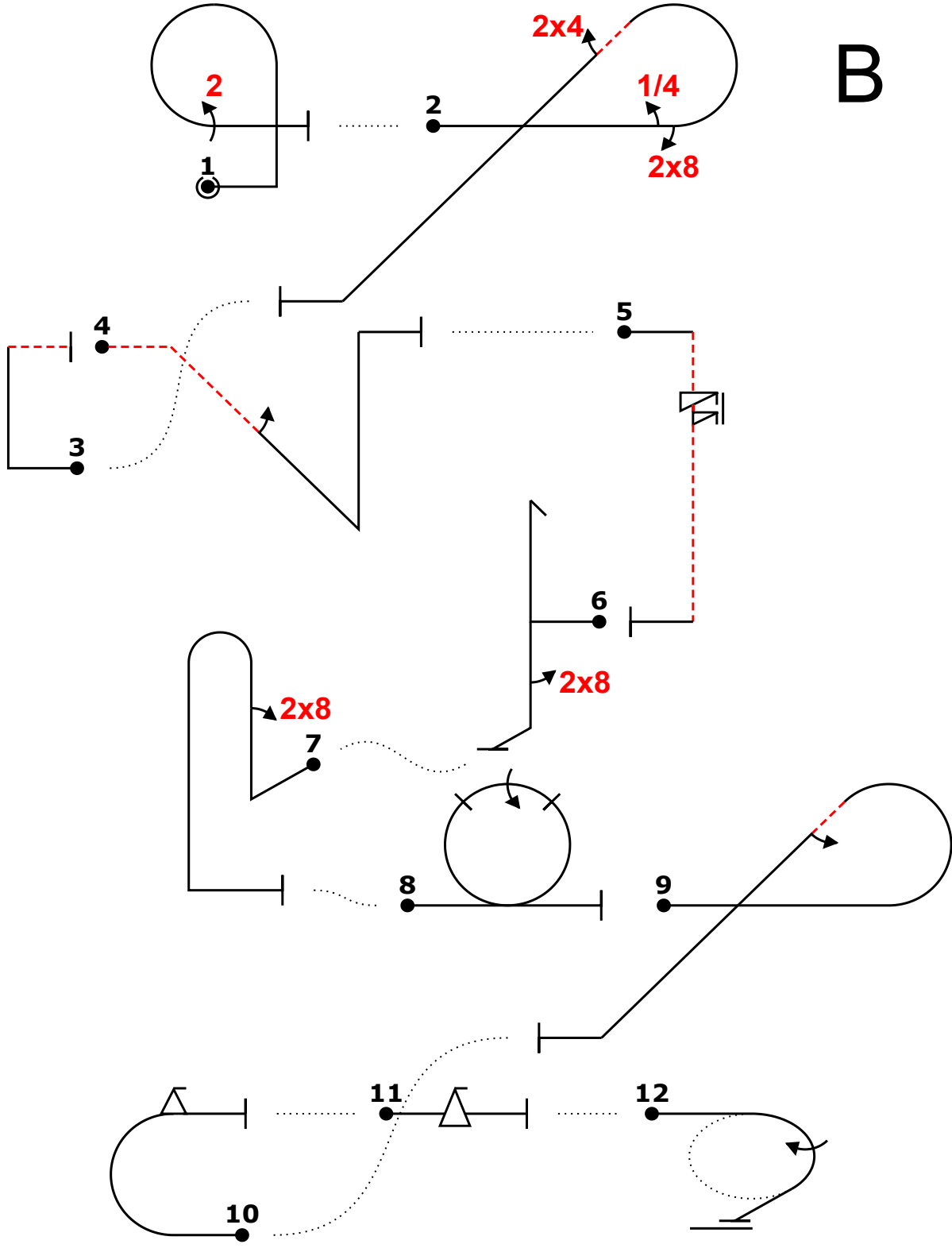
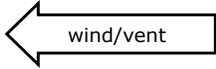

# B

Power			
Fig	Aresti	K	
1 E	8.6.1.1 9.2.3.4	11 9	20
2 G	8.5.6.1 9.1.3.1 9.8.3.1 9.4.4.2	10 2 3 5	20
3 Add.	1.1.7.1	9	12
4 F	1.2.4.4 9.1.4.2	13 4	17
5 A	1.1.6.3 9.11.1.6	10 3	13
6 H	5.2.1.1 9.8.5.1	17 3	20
7 J	8.4.1.1 9.8.1.1	13 7	20
8 C	7.4.1.1 9.1.3.4	10 8	18
9 Add.	8.5.6.1 9.1.4.2	10 4	12
10 D	7.2.2.1 9.9.3.2	6 11	17
11 B	1.1.1.1 9.9.3.4	2 11	13
12 I	2.1.3.1	14	14
<b>Total K = 196</b>			

